

## MAINTENANCE - INSTALLATION - OPERATION INSTRUCTIONS FOR EX-PROOF FANS

### Models and Intended Use

All products mentioned in this document can be used for the removal of explosive gases or dust from the environment in accordance with this Manual. All Models in category 2G/2D zone 1 and category 3G/3D zone 2 - must be protected by an additional Motor protection switch.

RSD series centrifugal fans are specifically designed for ventilation of Acidic and Corrosive environments. It is the ideal product to use when corrosive gases, polluted air or other aggressive components are part of the exhaust air. Typical applications are plating units, medical facilities, food, electrical, battery storage areas and the petrochemical industry.

**The propeller** is made of PP, PPS or PVDF material with statically and dynamically balanced, aerofoil 3D blade geometry, silent, highly efficient, back sloping structure. Static and Dynamically balanced in DIN 1940 norms. **The body** is made of corrosion and UV resistant PE material and there is a condensate drainage hose and tap on the body. Body angle can be changed by removing the bolts. **Fan base and support** is AISI 304 Quality Stainless steel. All fittings are A4/316 quality stainless steel. Standard production is suitable to operate in conveyed air temperature between -15°C / +70°C. Easy to maintain, the high-efficiency fully enclosed electric motor is out of the air stream and has IP55/IP65 protection. Speed control can only be provided by a frequency converter.



### Applications

The Gurvent brand fans have an explosion-proof asynchronous motor and the fan motor is directly coupled to the fan body. This design is generally produced to provide more air to the environment in explosive zones (ZONE1-ZONE2) and to remove it. All parts of the designed fan are antistatic or coated materials are used. During installation (at the blade ends) Gurvent centrifugal fans are designed according to ATEX 2014/34/EU and EEx II, T3, T4, T5, T6 EN 50 314/50 019 standard in case of direct coupling of the asynchronous motor to the fan body in the designs indicated with Ex.

### Safety Information

• The Fan Blades are specially designed to remove explosive gases (zone 1 category 2G - 2D and zone 2 category 3G). The fan is not suitable for environments with large solid particles. Suitable Models are available. The fan is not affected by explosive atmospheres under normal operating conditions. The motor windings have a high insulation class and can operate in extreme temperatures. The motor complies with EX-Proof. It is not affected by explosive / flammable gases and vapors. For the operating and operating ranges of the fans, please refer to the operating values.

### **Electrical connections must be made by competent persons during installation and the relevant instructions must be followed.**

- To prevent failure and protect the motor, PTO terminals are included in the Terminal Box. This protection prevents the motor from overheating. (standard II(2) G, rule94/4/EG). The PTO ends must always be connected to the Motor protection switch. The protections must be selected for the specific operating conditions according to standards EN60079-14 and EN61241-14.

- Electrical protections in the motor power supply may not be sufficient to protect against overloads. Connecting built-in protections to the windings solves this problem: PTO bimetallic probe (normally closed electromechanical device, opens when the threshold value is exceeded) closes the circuit when the temperature is reached.

The reset of this interrupt must only be performed manually, not automatically. The user must use a trip relay complying with IEC 61508, in accordance with the norms. The metal parts of Ex-Proof motors must be connected to an external earthing installation.

- Protectors, protection cages must be installed in place except for maintenance. In order to prevent particles that may be in the air drawn from the environment and damage to the blades, a grill should be placed on the fan suction side.

- In order to ensure that the choice of material used in the installation is correct, the warning notes in Draft N107-2:2003 (E) standard should be examined.

- In order to eliminate faults of the device that may arise due to improper use or force majeure and to take protective measures, the current DIN EN 292 and in particular Draft N107-2:2003 (E) must be applied. The system must be switched off during maintenance. If the product is connected to standard mains power supply, maintenance is carried out in accordance with EMC specification 89/336/EWG. During maintenance and service, the notes specified in the relevant instructions must be observed. Spare parts and other accessories of the product must be stored in a suitable place. It is recommended to use the Gurvent MK mounting base for installation. The installer is responsible for the proper connection of the fan.

### Transportation and Storage

- All fans are packaged in our factory in accordance with the desired transportation conditions.

- The fan(s) are either in their original packaging or suitable conditions have been made for transporting large fans (lifting arms, handling ring, lifting eyes for motors). Use suitable lifting materials. Do not transport by the connection cables of the fans!

Avoid excessive vibration and excessive impact. Be careful of damage to the packaging and fans. It is recommended until installation that the fans are stored in their original packaging in a dry, clean storage environment. Fans should not be exposed to very hot or cold ambient conditions.

If the fans remain in stock for more than one year, check the motor and devices.

There is a carrying hook on the fans. Fans can be lifted by connecting this part (Image 1).



Image



### Using FCP speed controller, Maintenance Switch in hazardous installation areas

• If the control devices such as frequency inverter device, maintenance switch, etc. are within the explosive zone, they must have ATEX certificate. The selection of cable cross-section suitable for the motor power and distance for products to be installed outside the zone is up to the user.

### MAINTENANCE

• The dimensions between the rotating and stationary parts must not be smaller than 1% of the fan diameter during maintenance. Bolt tightening values with torque wrench: 9.5 Nm for M6 and 23Nm for M8. Fittings must be tightened in such a way that they do not cause vibration during operation. When the motor shaft is installed vertically, the drain hole at the bottom of the shaft must always be open. Electrical connection diagram is on the stator or fan housing. For drain connection, hose ends are clipped. A liquid seal water removal pipe with a liquid gasket under the drain hole is supplied with the product for condensation that may occur in very humid, vaporous environments. (Image 2) If there is no vapor in the discharged air, the Valve can be closed. (Image 3)

According to the current fan installation direction, the drain valve (Image 2) must always be below. If necessary, the plug in Image 4 should be removed and replaced with the tap in Image 2. If the system is in areas exposed to lightning, lightning protection methods must be applied. Appropriate protection measures must be taken if the system is in areas closely exposed to radio waves.

- Bearings should be replaced after 40,000 operating hours. You can consult our maintenance department for the appropriate special spare parts that need to be replaced. Things to consider during service and maintenance: Make sure that the rotor of the device and the rotating parts connected to it have stopped. Make sure that the power is switched off until the maintenance work is finished. Personnel must observe safety rules. Installation must be carried out in such a way as to allow cleaning and inspection. Regular cleaning must be carried out to prevent motor imbalance.

- Do not use cleaning tools that are too hard and may cause damage when cleaning the fans.

- Pay attention to abnormal sounds! In case of faults, defects or deficiencies that may occur in the devices (For example: In cases such as cable bending, damage), please contact the maintenance service.



Image 2



Image 3

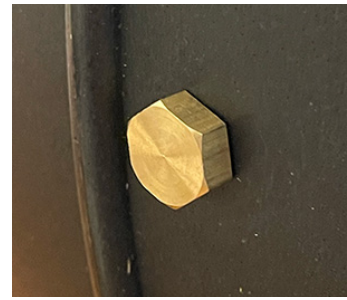

Image 4

- Operating values and technical information are on the label on the device. Voltage, current values are indicated. Do not exceed the permissible values and the nominal currents to be drawn. Value exceedances are indicated as (2%). **The permissible air temperature for maximum operation is +70°C and the density  $q=1.2 \text{ kg/m}^3$ .**

- Motor protection thermistor value DIN 44082-M and motor value are specified in the certificate (03ATEX 3045). The fan is under thermistor control according to the characteristic curves and permissible values. Operating regime, (number of Start-Stop) The engine complies with the continuous operation regime S1. Switch on and off must not be performed excessively frequently. Proper cooling of the heat generated in the motor during operation complies with EC certification requirements. Device operates according to the values indicated on the label. Operating outside these values may cause the fan to burn out.

**Revision :** For ATEX approved fans, reuse of repaired parts and replacement with equivalent parts is not permitted. If the fan is destroyed, it must be completely replaced with a new one

### **OPERATING CONDITIONS - COMMISSIONING - ( Actions to be taken before the operation is carried out)**

**Use chemical-resistant, spark-proof equipment and respirators as the fan will contain corrosive and explosive gases.**

- Inspect the product manually and visually, if there is any adverse condition, breakage, crushing, cracking or unwanted noise, contact the company you purchased the product from. Check the installation and electrical connection. Check that it is safe to touch. Inspect the fan blades to ensure that there is no friction and no sparking. Fan protection elements and grounding must be connected. Thermistors and devices must be properly connected. Check the inside of the electrical connection box. Installation and connections must be correct. Motor Electrical Connections must be made according to the label information. Otherwise the product is not covered by the warranty. To prevent unforeseen but potentially dangerous situations during commissioning: Check the air and rotation direction. Air and rotation direction must be in the direction of the arrow on the device. Switch the fan on and off for a short time (max. 3 sec) and check the direction of rotation. If the direction of rotation is wrong, replace the 2 phases. For monophase motors, please consult our company. Check for vibration and balance during operation. Take the necessary precautions to prevent dirt, corrosion and damages that may arise from environmental conditions during or after assembly. After installation, tidy up the materials left around and eliminate any deficiencies.

## POSSIBLE MALFUNCTIONS AND TROUBLESHOOTING METHODS

Possible Malfunction	Reason	Solution
If there is excessive vibration in the fan	Dust and foreign objects may be stuck on the propeller.	The propeller should be cleaned. Cleaning should be done more frequently, filters should be used.
	Foreign materials may have entered the bearings.	The bearing must be cleaned and replaced with a new one. If necessary, the fan should be replaced.
	The pedestal may have been installed incorrectly.	The pedestal must be leveled.
	The propeller or pulley may be out of balance.	The propeller must be rebalanced.
	There may be runout on the motor shaft / propeller hub.	Runout of the shaft / hub should be checked.
	The propeller may be rubbing against something (the body).	It must be checked and placed properly.
If the propeller wears out quickly,	The operating temperature of the fan may be too high.	The temperature should be checked.
	Dust filter may be clogged. / There may not be a fan suitable for the purpose	It must be replaced with a new one.
If it is not operating at the desired capacity,	There may be a tear in the ducts.	Connections in the ducts should be checked.
	The dust filter may be clogged.	They should be replaced with new ones.
	The fan may be rotating in the opposite direction.	Direction of rotation should be checked.
	The power of the fan may be insufficient.	Use a fan with a larger capacity.
Engine starts but heats up quickly	The parts of the fan may be rubbing.	Friction should be prevented.
	Motor capacity may be insufficient.	Larger power motor should be used.
If the electric motor is not running,	Phase Poles or switch may be connected incorrectly.	Electrical Installation should be checked. It may require maintenance by an electrician or coil winding master.
	The phase may be incomplete.	
	The switch may not be turned correctly or a lead may be broken.	
	The motor is not cooling down or the cooling propeller may be damaged.	
	The mains voltage may be low.	
	The thermal switch may be set incorrectly.	

### RSD SERIES DIMENSIONS

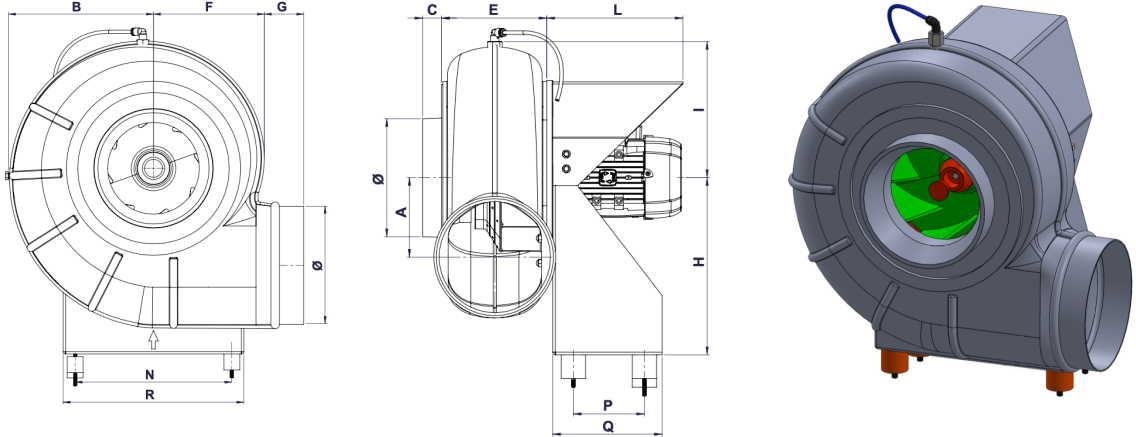

Model	A	B	C	Ø	E	F	G	H	I	L	N	P	Q	R	Vol. Weight	Weight	Box Size (mm)
RSD 18B	120	195	35	160	148	158	55	300	230	200	220	85	140	235	33	11-12	460x435x510
RSD 20B	120	195	35	160	148	158	55	300	230	200	220	85	140	235	33	11-12	460x435x510
RSD 22B	135	250	35	200	180	200	60	300	230	230	285	120	140	290	47	14-15	560x470x610
RSD 25B	135	250	35	200	180	200	60	300	230	230	285	120	140	290	47	13-15	560x470x610
RSD 28B	182	275	35	225	186	210	75	350	245	250	295	188	190	320	68	20-22	610x530x720
RSD 31B	230	320	35	250	205	225	60	415	270	250	332	135	230	355	67	20-26	670x540x720
RSD 35B	245	335	40	280	230	275	135	430	290	280	407	145	230	385	89	25-32	785x600x875
RSD 40B	260	385	40	315	260	295	130	515	340	350	427	222	250	370	95	30-35	865x700x1020
RSD 45B	325	395	45	355	255	325	100	635	340	350	507	282	250	410	110	37-42	890x710x1200

PRODUCT WEIGHTS MAY DIFFER ACCORDING TO ENGINE POWER. .



**ELECTRIC MOTOR CONNECTION METHODS**

**STAR CONNECTION (MAX. 4KW)**

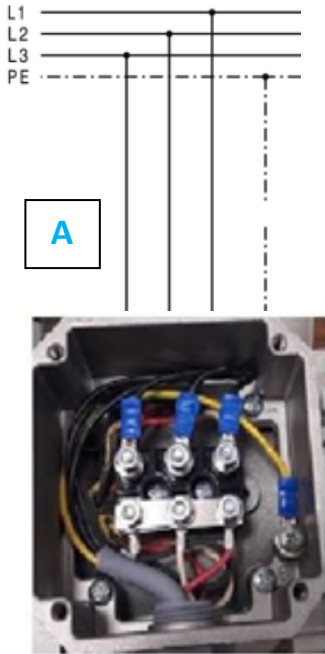

**DELTA CONNECTION (5.50 KW AND ABOVE)**

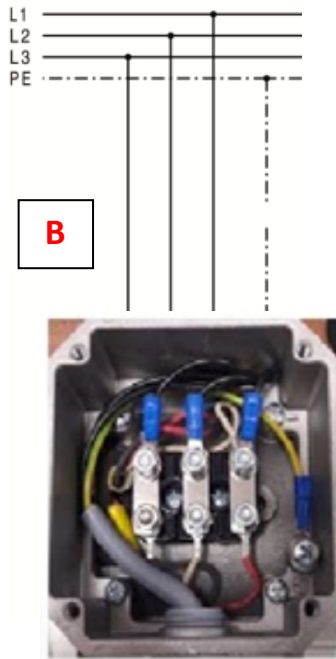

**MOTOR PROTECTION SWITCH**

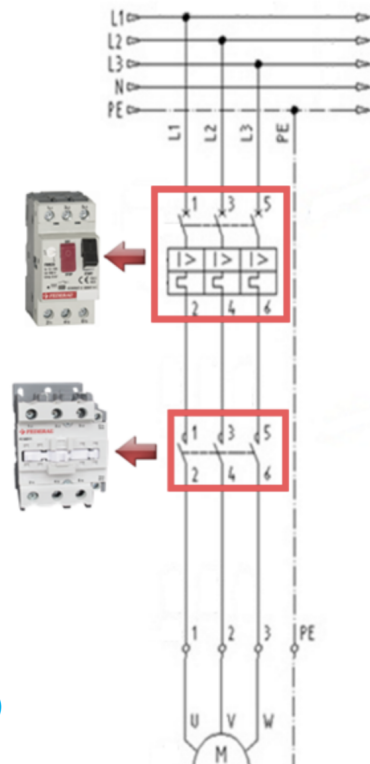

- \* Under normal conditions, 380V electric motors are made star connection (A)
- \* 5.50 Kw and above Electric Motors Delta connection (B) is made.

**Matters to be carefully considered about Frequency Drive connection**

- \* Delta connection is made if your drive is suitable for 220V supply input - 380V motor connection output, that is, if the motor is 380V.
- \* Star connection is made if your drive is suitable for 380V supply input - 380V motor connection output, that is, if the motor is 380V.

